

CPX TRIPLEX MEDICAL VACUUM PLANT **INSTALLATION, OPERATIONS & MAINTENANCE** **MANUAL**

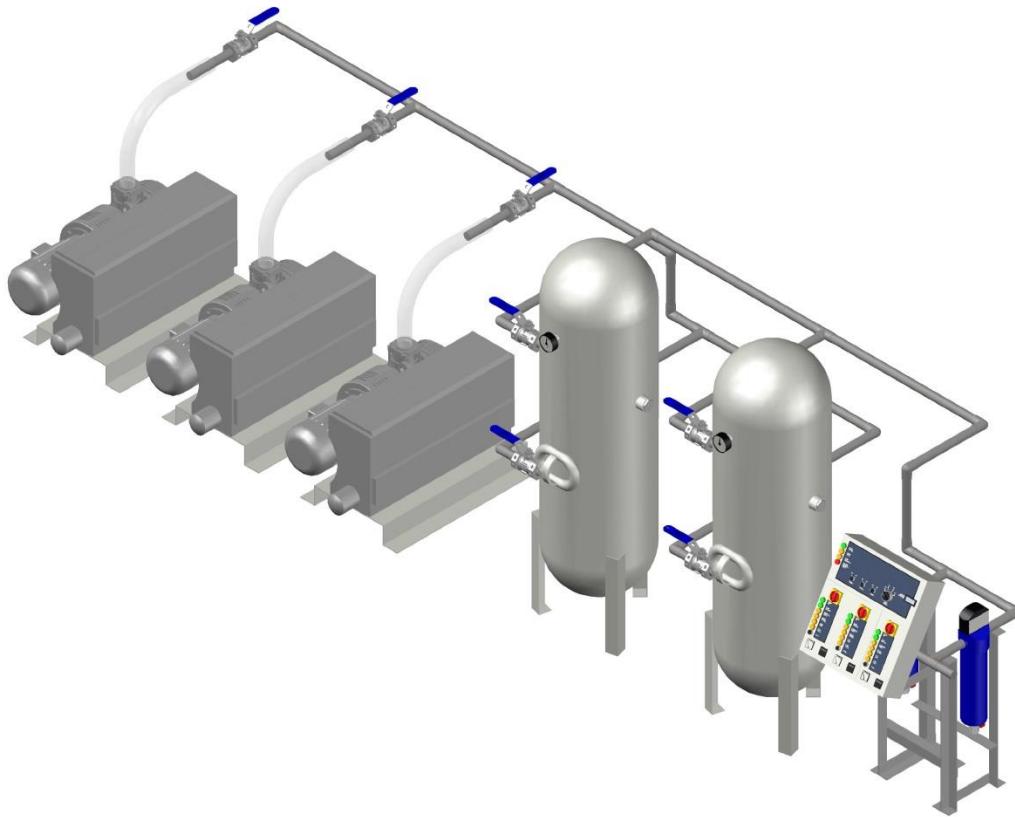

VERSION HISTORY

Version #	Implemented By	Revision Date	Approved By	Approval Date	Reason
1.0	David Evans	17/07/2014			
2.0	Matthew Dean	06/08/2015			

TABLE OF CONTENTS

1. SAFETY	4
2. PRODUCT DESCRIPTION	5
3. INSTALLATION	7
4. ELECTRICAL SCHEMATICS	9
5. OPERATION.....	13
6. MAINTENANCE	14
7. SPARE PARTS.....	18
8. WARRANTY	18
9. CONTACT US.....	19
10. REGULATORY REQUIREMENTS	20
11. APPENDIX A: OPERATIONS & MAINTENANCE MANUAL APPROVAL	21

SAFETY

Qualified Personnel

Qualified personnel are persons who, due to their training, experience, instruction, and their knowledge of the relevant standards, can competently undertake the work required for the installation, operation and maintenance of this product.

General

This equipment should be installed, operated and maintained by personnel who are suitably trained, are fully conversant with HTM 02-01 and are familiar with this product.

Medical Gases

No attempt should be made to use or modify this equipment for use with a gas other than as identified.

This equipment should not be operated at pressures exceeding those stated in HTM 02-01 and this manual.

Electrical

All electrical work must be carried out by qualified persons. Connection cables must be selected according to the type of use and to the relevant voltage and current levels associated with the plant. Connect the plant in accordance with the circuit diagrams and any local wiring regulations. If you have any reservations about works to be carried out contact the manufacturer.



The noise level produced by the pumps will increase with the capacity of the supply system. For larger systems this can result in an unacceptable noise level at the pump

Power (kW)	Noise level (dBA)
5	75
5.1-15	82
15	89

EAR DEFENDERS MUST BE WORN WHILE PLANT IS OPERATIONAL

PLEASE NOTE:

It is a requirement to provide a 415V 3 phase supply for each motor starter, controlled by a separate sub-circuit. Fuses should be fitted based on the information shown in the table below.

FUSE LINK (Amps)	D.O.L. STARTING	
	F.L.C. (max)	kW (approx)
6	1.5	0.37
10	3.9	1.5
16	6.25	2.2
20	7.75	3.7
25	10	3.7
32	12.2	5.6
40	17.2	7.5

PRODUCT DESCRIPTION

General.

The Plant consists of;

A vertical Vacuum Receiver fitted with a Drain Valve and Vacuum Gauge.

Three oil flooded Rotary Vane Vacuum Pumps, 415V 3 phase 50Hz (other voltages and frequencies available on request), All pumps are capable of achieving greater than 650mmHg. The pumps are rated for continuous use and can withstand extended periods of running with high levels of vacuum. Each pump includes an inlet filter built into the inlet port housing to protect the pump from suspended particles and other debris. A pump failed vacuum switch is mounted on the pump, and is wired back to the control panel. This switch gives confirmation that the pump is actually operational and producing vacuum. Each pump is fitted with Flexible Hoses for Inlet and Exhaust pipework.

Bacterial Filters.

The plant incorporates duplex bacterial filters of the highest quality. Isolating valves are incorporated to enable the selection of duty and standby filter assemblies, and also enables replacement of an element while maintaining the operation of the plant. Each filter consists of a replaceable element within a sterilized drain flask with isolating valve and differential pressure indicator to advise when the element needs replacing.

FILTER MODEL	PIPE SIZE	FREE AIR CAPACITY AT ATMOSPHERIC PRESSURE			RAREFIED AIR CAPACITY AT 500 mm Hg VACUUM			ELEMENT MODEL	NUMBER OF ELEMENTS	DIMENSIONS mm				WEIGHT		DIMENSIONS inch				FILTER MODEL
		L/min	SCFM	Nm³/h	L/min	SCFM	Nm³/h			A	B	C	D	Kg	lb	A	B	C	D	
A27 MV	1/4	30	1	1.8	90	3	4.2	E511 MV	1	88	32	340	100	1.0	2.2	3 1/2	2	13	4	A27 MV
A39 MV	3/8	100	3.5	6	300	10.5	18	E511 MV	1	88	32	340	100	1.3	2.9	3 1/2	2	13	4	A39 MV
A56 MV	1/2	200	7	12	600	21	36	E521 MV	1	88	32	390	100	1.5	3.3	3 1/2	2	15	4	A56 MV
A70 MV	3/4	250	9	15	750	27	45	E521 MV	1	88	32	390	100	1.5	3.3	3 1/2	2	15	4	A70 MV
A105MV	1	600	21	36	1800	63	108	E811 MV	1	125	39	390	100	2.7	6.0	5	2	15	4	A105MV
A126 MV	1 1/4	1200	42	72	3600	126	216	E821 MV	1	125	39	540	150	3.5	7.7	5	2	21	6	A126 MV
A153 MV	1 1/2	2000	70	120	6000	210	360	E831 MV	1	135	50	570	200	4.4	9.7	5 1/2	2	22	8	A153 MV
A205 MV	2	3000	106	180	9000	318	540	E851 MV	1	135	50	770	200	5.0	11.0	5 1/2	2	30	8	A205 MV
A306 MV	3	4000	141	240	12000	423	720	E1261 MV	1	200	68	950	200	15.5	34.2	7 7/8	3	37	8	A306 MV
A308 MV	3	5000	177	300	15000	531	900	E1281 MV	1	230	65	1075	300	19	41.9	9	3	42	12	A308 MV
A391 MV	DN 80	5500	194	330	16500	582	990	E139 MV	1	450	300	940	700	58	128	17 3/4	12	37	28	A391 MV
A483 MV	DN 100	6765	238	406	20295	714	1218	E88 MV	3	520	300	960	700	74	163	20 1/2	12	38	28	A483 MV
A484 MV	DN 100	8200	289	492	24600	867	1476	E88 MV	4	520	300	960	700	74	163	20 1/2	12	38	28	A484 MV
A686 MV	DN 150	11000	388	660	33000	1164	1980	E88 MV	6	680	400	1000	700	165	364	26 3/4	16	40	28	A686 MV

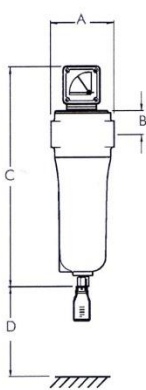

A27 MV to A308 MV

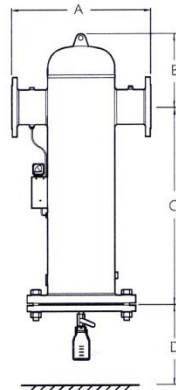

A391 MV to A686 MV

SPECIFICATION	Grade MV	
Penetration to BS 3928	< 0.005%	
Maximum temperature	100°C	212°F
Pressure loss - clean	35 mbar	0.5 psi
Pressure loss - change element	100 mbar	1.5 psi
Maximum working pressure	7 barg (see note 10)	100 psig (see note 10)
Maximum working vacuum	1013 mbar	15 psi
Element end cap colour	black	

Control Panel.

The three Pump Control Panels comprise of an Isolator, Manual Motor Breakers, Contactors, Hours Counters, Ammeters, Indicators for; Mains On, Pump Operating, Control Circuit Failed, Motor Tripped, and Pump over Temperature. Each Pump has a Reset button and an Auto/Manual Switch.

A Control Unit incorporating a Vacuum Gauge, Control Pressure Sensors, a Duty Selector Switch, an Auto/Manual Switch for each pump, a PLC and relays for alarm contacts.

All Alarm Contacts are duplicate allowing complete dual Alarm System or BMS/Alarm Connection.

Motor Protection.

Each Pump Motor has a Manual Motor Breaker and Contactor. They operate when the motor connected draws excessive current or if a phase is lost.

The trip current is set on the disc on the front of the breaker at the factory and should not need adjustment. There is a Manual Switch that allows testing of the unit.

GENERAL NOTE; it is recommended that all electrical work be carried out by a qualified electrician.

INSTALLATION

Mechanical

The plant is designed to be floor mounted by means of suitable floor fixings through the legs of the receiver. The mounting holes in the baseplate of the plant are 12mm diameter.

Siting

The plant should be easily accessible, and should allow for all round access, for maintenance purposes.

The plant room temperature should be maintained in accordance with HTM 02-01. Oil flooded machines suffer from oil emulsification at low temperatures due to heated gases being drawn into the pumps via the intake, which condense and mix with the oil. Therefore the plant room may need to be heated.

Pipe work Connections

All soldered joints must be made by using inert gas soldering techniques, to prevent the pipeline from becoming contaminated.

A Stub located on the inlet side of the filters provides the Pipeline connection to the Plant. Exhaust Pipe Work from each pump should be installed out to atmosphere using the shortest possible route.

Where long or torturous pipe runs are unavoidable consideration should be given to increasing pipe diameters. Exhaust Outlets should be terminated with a mesh guard or similar to prevent small birds and insects entering the Pipe Work.

Any obstruction in the Exhaust Pipe Work will reduce Plant performance.

Always point Pipe Work downwards at termination to reduce rainwater penetration.

Electrical

Electrical power supply should be provided via three, three phase + neutral + earth supplies and according to the table on page 3 of this manual.

Connections should be made to the simplified wiring diagram.

ELECTRICAL SCHEMATICS

Medical Vacuum Plant Connection Diagrams

Triplex Medical vacuum plant connection diagram

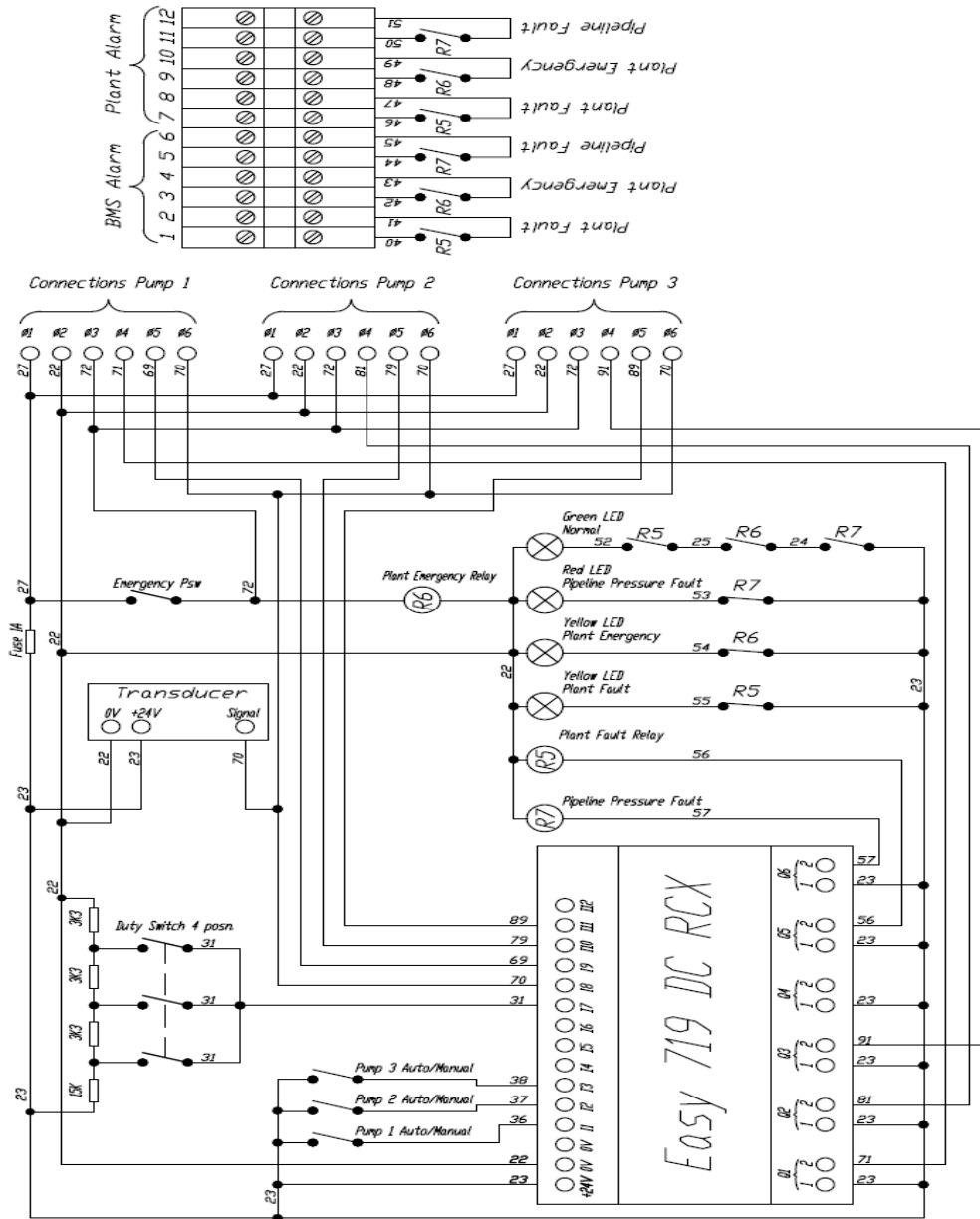

Triplex vacuum plant control wiring diagram

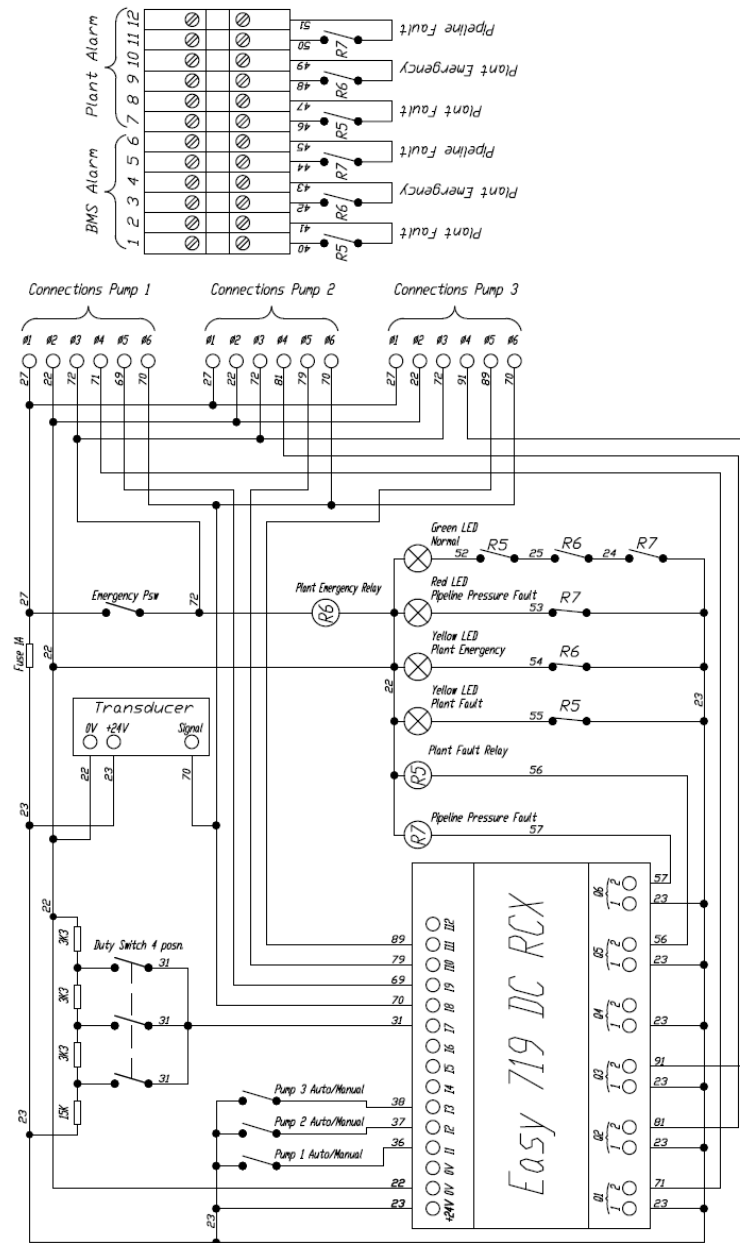

Pump Starter wiring diagram

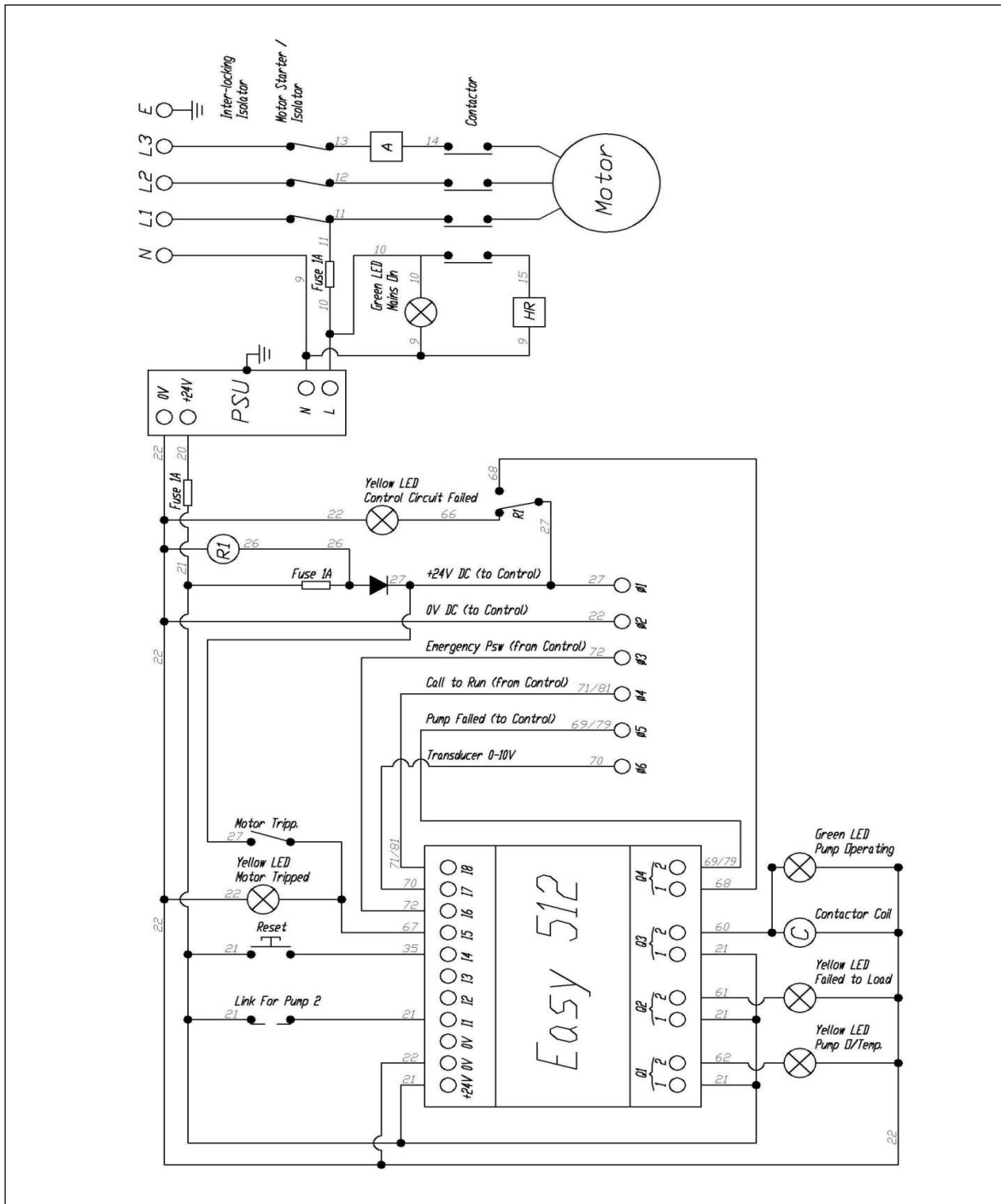

Vacuum plant pneumatic schematics

Triplex Vacuum plant pneumatic schematic

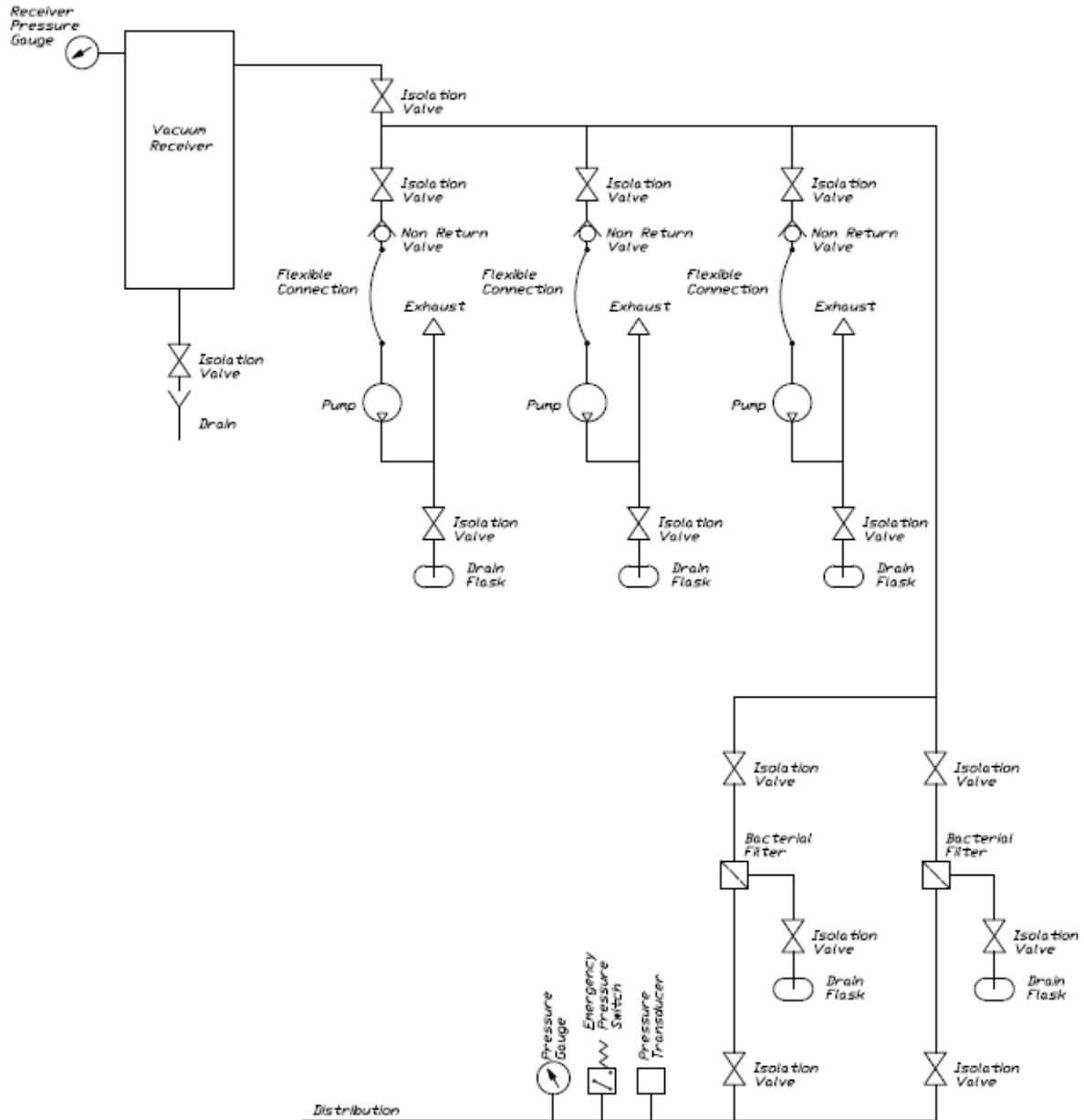

OPERATION

Initial Powering Up

- Check pump oil levels are O.K. top up if necessary
- Switch the Auto/Manual Switch to Manual, this will ensure the pump starts immediately.
- Switch the isolator on pump number 1 starter to the on position.
- Quickly note the direction of rotation of the pump number 1 and switch the isolator off again.
- Put the Auto/Manual Switch to Auto Position.
- If rotation is incorrect swap round two of the incoming phase to the panel (do not alter any of the wiring inside the panel).
- Repeat for pump number 2 & 3.
- Once it is established that all pumps are rotating in the correct direction the plant can be brought on line after a few initial checks:-
 1. Ensure that the pump isolation valves are all in the open position
 2. Ensure that one bacterial filter is valved open as duty and the other closed for standby.
 3. Ensure that the drain valve at the base of the vessel is closed
 4. Ensure that all pipe work connected to the plant is appropriate.
- On the center 'control panel' ensure that the Duty selector switch is in the auto position. This is the default position and will cycle the duty pump every time a pump is called to run.
- Switch all the pump isolators to the on position. The primary pump will start to run shortly followed by the secondary and then the reserve.
- All pumps will run until a pressure of 650mmHg is achieved.
- If any Fault indicators are still illuminated after start up simply press reset this will only occur after initial start-up depending how long the system takes to pressurize
- The plant can now be left to operate normally.

General

Normal operation

When a demand is put on the plant the primary pump will start at 510mmHg and will run until a pressure of 650mmHg is achieved, if the pump is unable to cope with the demand the secondary pump will start at 485mmHg and both will run until a pressure of 650mmHg is achieved.

If the primary and secondary pumps combined are still unable to cope with the demand then the reserve pump will start at 460mmHg and all 3 will run until a pressure of 650mmHg is achieved.

The Auto cycling of duty pump can be prevented by manually selecting either 1, 2 or 3 as duty using the selector switch located on the center control panel.

Specialists in HTM02-01 Medical Gas Pipeline Equipment

The pumps can be made to run continuously, regardless of pressure by switching the Auto/Manual switch on the pump starter to manual. The reset button on the pump starter can be used to clear any of the fault indicators on the pump starter after the faults have been rectified.

EMERGENCY OPERATION

If for any reason none of the pumps start the plant will run on the emergency pressure switch set at 420mmHg, the yellow plant fault indicator will illuminate, and will call the primary pump to run for a minimum time of 10 minutes.

If after 20 seconds the pressure has not sufficient not risen above 420mmHg the secondary pump will start and run for a minimum of 10 minutes.

If after a further 20 seconds the pressure still has not sufficiently not risen above 420mmHg the reserve pump will start and run for a minimum of 10 minutes.

If the plant fault Lamp remains illuminated after the 10 minute pump run period the pump will continue to run until the lamp extinguishes.

If the pressure falls below 360mmHg the Red Pipeline pressure fault Indicator will illuminate.

MAINTENANCE

General

The two most important items to consider are oil and filters.

- Oil should be changed every 6 months or 1000 hours whichever comes first.
- Filters should be used individually and replaced at 12-month intervals.
- The plant should be in a controlled plant room with access limited to engineering staff only.
- Keep a daily logbook to record maintenance work carried out.

Routine Maintenance

DAILY.

- Oil levels should be visually checked, and topped up as required with vacuum pump oil. Screw off the oil inlet cover and fill up to the maximum of the inspection glass located on the side of the pump. It is expected that a small amount of oil will need to be added every 1 or two weeks. Each oil check and top up should be recorded in the logbook.
- Visually check the Medical vacuum filter differential pressure gauges, to ensure that the filter element is still working efficiently. Each inspection should be recorded in the logbook. If the differential pressure gauge indicates fail, the integrity of the system is not compromised, however the flow may be reduced, and the power consumption will be increased. In this case the element will need to be replaced.
- Visually inspect the plant for obvious signs of damage, or faults, or unusual noises.

WEEKLY.

- Observe all pumps whilst running, and record the ammeter readings in the logbook. This will indicate correct operation of the pumps.
- Check pump exhaust condensation drain traps, for accumulation of moisture, and empty if required. This condensation is due to the cooling of warm air in the exhaust pipework when the pump stops. This condensation is perfectly normal.
- Check Medical vacuum filter condensation drain traps, for accumulation of moisture, and empty if required. This condensation is due to the cooling of warm air in the filter bowl when there is no flow requirement through the filter. This condensation is perfectly normal. As this is connected to the medical vacuum supply, the contents should be treated as bio-hazardous. It is expected that this condensation will only need to be removed every two or three months as the moisture held in a vacuum is very little.
- Drain any moisture from the Receiver, using the manual drain valve.
- Change Duty Pump, (unless auto duty is selected on the main control panel).

MONTHLY (IN ADDITION TO THE ABOVE).

- Check Drain on Receiver using Valve.
- Check each Pump runs O.K. using Auto and Manual Switches (run for no less than 10 minutes each Pump).

EVERY SIX MONTHS.

- Check Pressure Sensor Cut In/ Cut Out Point of Duty.

Specialists in HTM02-01 Medical Gas Pipeline Equipment

- Change the duty filter, check the condition of the filter, replace if necessary.
- Change Oil in Pumps.
- Remove and replace medical vacuum filter elements, and 'O' ring seal on filter bowl. Record this in the logbook. The used parts should be treated as bio-hazardous.
- Check wiring connections are tight and secure.

EVERY 12 MONTHS.

- Drain and replace oil and oil filter in both pumps, check the condition of the oil, check for debris or suspended particles. The draining down of the pumps should be done one at a time to prevent the need for system shutdown. All maintenance carried out should be recorded in the logbook.
- Remove any build up of dust or other contamination from each pump.
- Check pressure switch settings and use a calibrated gauge, to gauge accuracy. Record the results in the logbook.
- Check that the pumps are securely mounted to the baseplate, tighten if necessary.
- Check overall plant operation and monitoring and warning alarm system.
- Re-commission plant to check each pumps performance and correct operation of plant
- Check wiring connections are tight and secure.
- Change Bacterial Filter(s).

Vessel Maintenance

Periodic insurance inspection will be required on the Pressure Vessel. The Vessel is provided with two inspection ports, one on each end.

Fault Diagnosis

SYMPTOM	FAULT	ACTION
Motor will not start	Circuit breaker Tripped/blown.	Check all Electrical Switchgear, Cables and Motor.
Pump Failed	Motor burnt out.	Return Pump for repair.
	Overload tripped	Isolate Supply Power, Reset Overload Trip.
Motor overheats,	Inlet to Motor Fan or After Cooler is not obstructed.	Ensure the Pumps are not covered, and that air flow is available to the Motors.
Standby Run Lamp, On,	Duty Pump failed.	Check Motor is running.
	Plant overuse.	Check sizing.
Low Vacuum Output, Permanently Open Circuit	Vacuum Failure	Check Motor is Running. Check Thermal Overloads not tripped. Check operation of vacuum Switches. Check electrical connections on Control Circuit Check Flexible Hoses and connections; replace if damaged

SPARE PARTS

5 Liters of vacuum pump oil

VACOIL5

1 x Bacterial Filter
panel

please specify batch number of Plant located inside control panel

WARRANTY

The CPX automatic manifolds comes with a 12 month warranty from day of shipment. Within this period Precision UK will repair, replace any part on site, or at the factory, which is proven defective at Precision UK's cost.

Furthermore, Precision UK will warrant its materials to be free from defects for an additional period of four (4) years (five (5) in total from date of shipment). Within this period Precision UK will replace any part, at no charge, which is proven to be defective. Shipping cost after the first twelve (12) months will be borne by the customer.

This warranty is valid when the product has been properly installed according to Precision UK's specifications, used in a normal manner and serviced according to the factory recommendations. It does not cover failure due to damage which occurs in shipments or failures which resulted from accidents, misuse, abuse, neglect, mishandling, alteration, misapplication or damage that may be attributable to acts of god.

Precision UK shall not be liable for incidental or consequential damages resulting from the use of this equipment.

CONTACT US

CPX Technology Building, Pepper Road, Hazel Grove,
Stockport, Cheshire, SK7 5BW, UK

Tel: +44 (0) 161 487 2822

Fax: +44 (0) 161 487 2816

Email: info@precisionuk.co.uk



REGULATORY REQUIREMENTS

The following British, European and International Standards have been consulted during the design, manufacture and testing of the CPX Medical Vacuum Plant.

√ BS EN 737-3:2000	Medical gas pipeline systems – Part 3: Pipelines for compressed medical gases and vacuum.
√ BS EN 14971:2012	Medical Devices. Risk Analysis
√ BS EN 13348:2001	Copper and copper alloys. Seamless round copper tubes for medical gases or vacuum.
√ BS EN ISO 17672	Brazing. Filler metals.
√ BS EN 980:1997	Graphical symbols for use in the labelling of medical devices.
√ ISO 7396-1	Medical gas pipeline systems. Pipeline systems for compressed medical gases and vacuum.
√ ISO 554	Standard atmospheres for conditioning and/or testing. Specifications.
√ SS 01 91 02	Colour atlas
√ BS EN 60601-1	Medical electrical equipment. General requirements for basic safety.
√ HTM 2022	Medical gas pipeline systems. Design, installation, validation and verification.
√ HTM 02-01	Medical gas pipeline systems. Design, installation, validation and verification.
√ C11	NHS model engineering specification – medical gases.
√ BS EN 286:1991	Simple unfired pressure vessels designed to contain air or nitrogen. Design, manufacture and testing.
√ BS 5169:1992	Specification for fusion welded steel air receivers.

APPENDIX A: OPERATIONS & MAINTENANCE MANUAL APPROVAL

The undersigned acknowledge they have reviewed the automatic manifold **Installation, O&M Manual Template** and agree with the approach it presents. Changes to this **O&M Manual Template** will be coordinated with and approved by the undersigned or their designated representatives.

Signature: _____ Date: _____
Print Name: _____
Title: _____
Role: _____

Signature: _____ Date: _____
Print Name: _____
Title: _____
Role: _____

Signature: _____ Date: _____
Print Name: _____
Title: _____
Role: _____